

Videosec[®]



KRC2206-W

Wi-Fi Roller Shutter Controller

1 Product Description

Wi-Fi Roller Shutter Controller supports Wi-Fi 2.4G and RF 433, which can be controlled by Tuya App and wireless kinetic switch. It reserves the input terminals for traditional switches, and can control the the roller shutter by the original traditional switches. It is mounted in the box of switch. Through the smart speaker, it can achieve ON/OFF/STOP by voice control. (Smart speakers like Google Assistant, Amazon Alex).

2. Technical Parameters

Project	Parameters
Product Model	KRC2206-W
Operating Voltage	AC100V -240V 50/60Hz
Maximum Current	1.7A
Maximum Power	reactive load 374W (220V~input)
Communication Way	WiFi IEEE 802.11 b/g/n 2.4G & RF 433MHz
Communication Distance	80m (Outdoor) 25m (Indoor)
Standby Power Consumption	< 1W
Storage Capacity	Each channel can store up to 10 wireless kinetic switch info
Wiring Method	Terminals
Installation Method	the box of switch
Product Size	L44*W44*H22mm
RF Receive Sensitivity	-110dBm
Work Temperature	-20°C ~ +55°C
IP Rating	IP20
Executive Standard	EN60669-1:2018 EN IEC55015:2019
Certification Requirements	CE/ROHS

3. Wiring Diagram

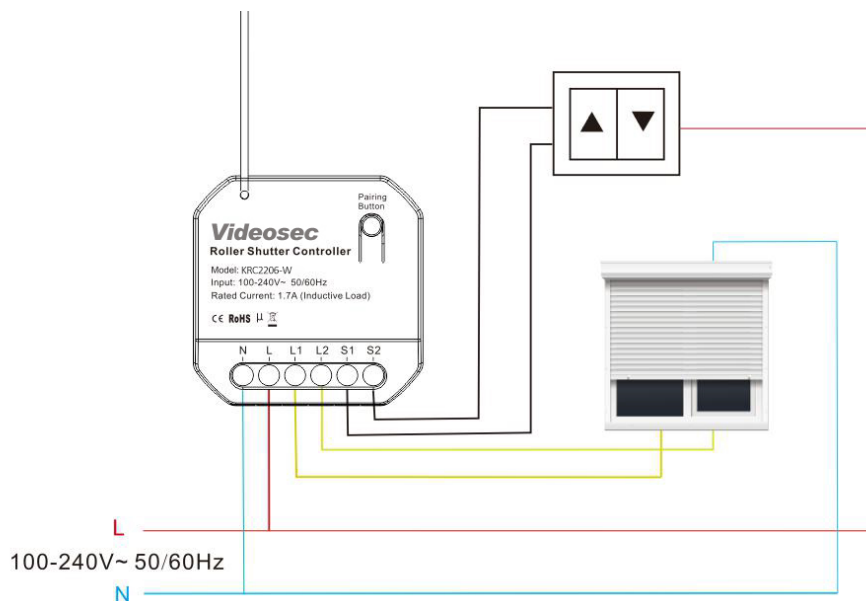

N: Input Neutral Cable

L: Input Live Cable

S1: Traditional switch forward rotation input (roller shutter opening)

S2: Traditional switch reverse rotation input (roller shutter closing)

L1: The output of the motor forward switch

L2: The output of the motor reverse switch

4. Control Method

It reserves the input terminals for traditional switches

It must be controlled after pairing with wireless switch more than two keys.

When pairing with the two-button switch, the left button controls L1 by default, and the right button controls L2 by default.

When pairing the three-button switch, the middle button is the pause button by default.

Press a button to switch between the two states of rotation and stop.

If press the button in the opposite direction during rotation, it will stop for 1 second and then rotate in the opposite direction.

5. Product Features

5.1 Network Method

After the Receiver is powered on, it enters the network configuration (EZ mode) by default, and the LED1 light flashes quickly (2 flashes per second). If LED1 light is not in right state, need to reset the device to enter the network configuration mode, follow the steps below: Press the button for 10 seconds, then release the button after the light is still, and when the LED1 light is flashing quickly, it means that it enters the network configuration state. After entering the network configuration mode, it can add devices through the App of "Tuya Smart" or " Smart Life". After the device is successfully added, it can achieve ON/OFF by App control.

If the controller network cannot be configured successfully in "EZ mode", try "AP mode". Follow the steps to switch to the "AP mode": press the button for 10 seconds in "EZ mode "(When LED1 light flash quickly), then release the button after the light is still, and it can switch to "AP mode". At this time, the light will turn off once every 2 seconds. If need to switch it from "AP mode" back to "EZ mode", press the button for 10 seconds, then release the button after the light is still.

5.2 The Pairing Method for Wireless Kinetic Switch

5.2.1 The pairing method

5.2.1.1 App Method

Enter the App page, click "Pairing" -> "Start Pairing", and select the corresponding channel. After the App page displays "waiting for pairing", press the corresponding button of the wireless kinetic switch that needs to be paired. It can complete the pairing. (the App will prompt "Pairing succeeded" after the pairing is completed.)



5.2.1.2 Physical button Mode

Press the button for 3 seconds, the light will enter the slow flashing state (1 flash in 1 second is a slow flash), it enters the status of "waiting for pairing". At this time, press the button of the wireless switch that needs to be paired once, and the light is off, it means that the pairing is completed.

5.3 Cancel Pairing with Wireless Kinetic Switch

5.3.1 App Method

Enter the App page, click "Pairing" -> "Clear Pairing", and select the corresponding channel. After the clearing is completed, the app will prompt "Clearing Successful".

5.3.2 Physical button Mode

Press the button for 12 seconds, the light will flash-still-off, and then release the button, all information for the wireless kinetic switch that matched with this channel will be cleared.

5.4 Clear Network

5.4.1 App Method

Enter the App page, click "Pairing" -> "Clear Pairing", and select the corresponding channel. After the clearing is completed, the app will prompt "Clearing Successful".

5.4.2 Physical button Mode

Press the corresponding button of receiver for 12 seconds, the light will flash-still-off, and then release the button, all information for the wireless kinetic switch that matched with this channel will be cleared.

5.5 Bridging Mode

Press the button for 7 seconds, LED1 changes from slow flashing to fast flashing (2 flashes per second), and release the button when it flashes quickly, and the receiver enters the bridging mode. At this time, the light flashes once every 2 seconds. If need to exit the bridging mode, just repeat the above steps.

6. Installation Diagram



the box of switch

7. Product Size

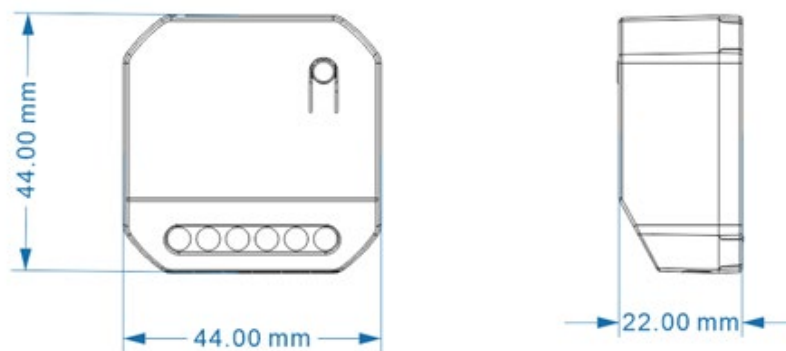

8. Application Environment

